

Sikkemaskin RAS 11.15 med hånddrift

Sikkemaskinen leveres med 9 par trinser.

Trinsemiddelavstand	50 mm
Arbeidsdybde maks (utladning)	200 mm
Platetykkelse maks ved 400 N/mm ² fasthet	1.25 mm



9 par trinser inkludert:



Sikketrinser
V1, V1.5, V2, V3

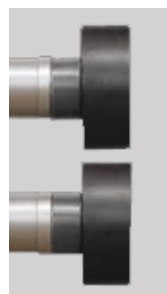

Sveifetrinser glatt
BB



Skrå dobbelt-
falstrinser 6 mm



Berteltrinser BC
H=1 mm



Kassettrinser
B1=4 mm
B2=6 mm
T=5.5 mm



Krympetrinser
B=20 mm

Trinsene er brunert, for korrosjonsbeskyttelse.

De fleste trinsene er herdet.

Maskinen er pakket i kartong og er egnet for pakkefrakt.



Alternativ: Maskinen montert på stender, inkl. 2 trinsebeholdere

Tilvalg:

Delt anslag

Med stor anslagsflate (240 x 160 mm)

Utføring:

- Slitesterk
- Plasma-nitrert



Isoleranslag

Anslagsdybde maks 63 mm



Rundtanslag for innvendig kant på plater

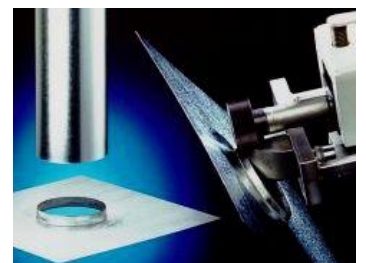

Anslag for skrå berteltrinser BD

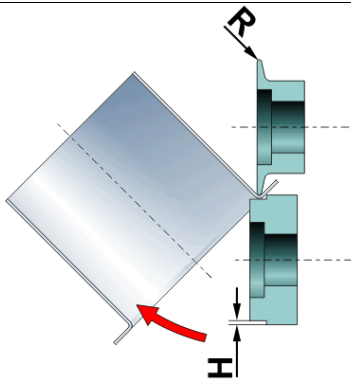
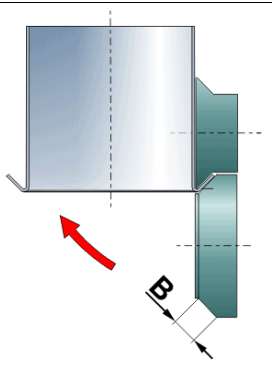
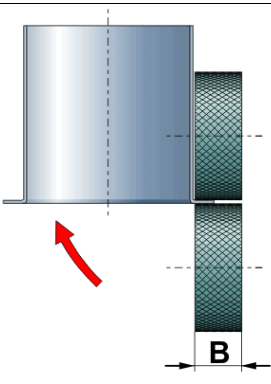
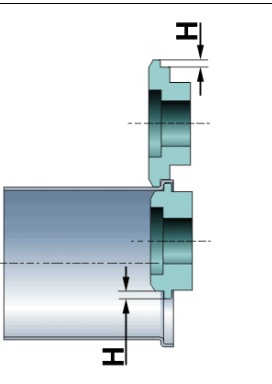
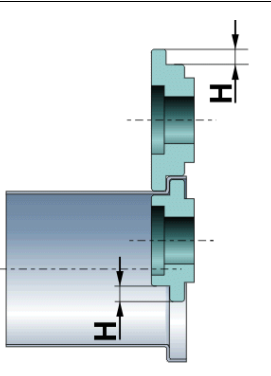
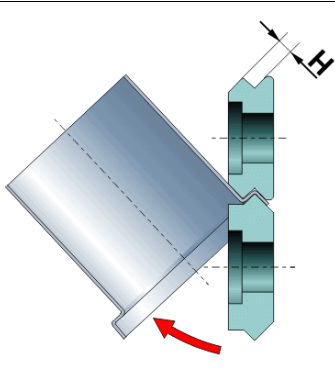

<p>Berteltrinser BC</p> 	<p>Skrå berteltrinser BD (Anslag 211234 er nødvendig)</p> 
<p>Sveifetrinser BB (riflet)</p> 	<p>Falstrinser F3</p> 
<p>Dobbeltfalstrinser</p> 	<p>Skrå dobbeltfalstrinser</p> 

Sikke-trinser

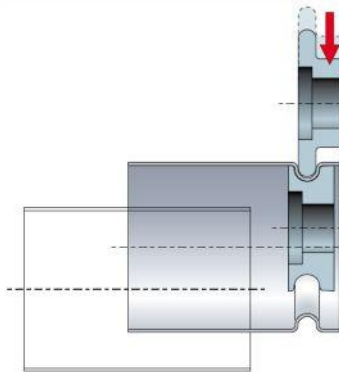

Sikke-trinser med spor på midten

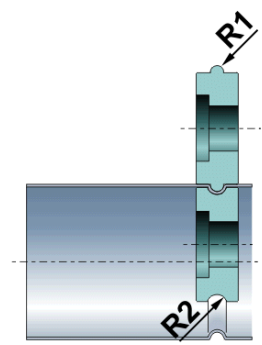

Kassetrinser

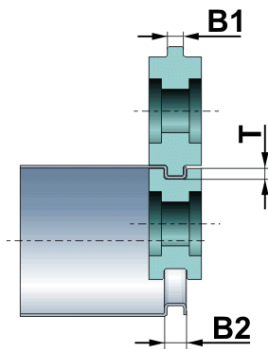

Krympetrinser

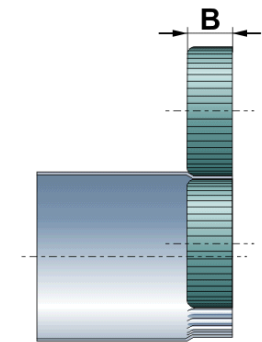

Krympetrinser med sikk

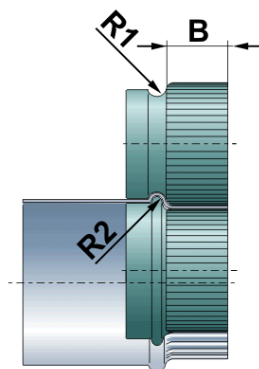

Kakeformtrinser

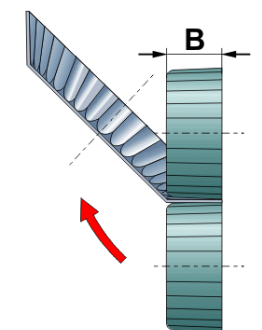

Skrusikke-trinser

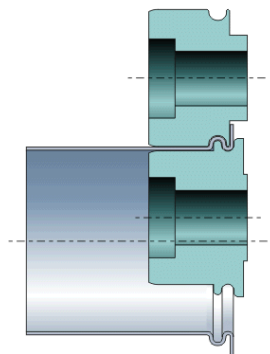

Trådnleggstrinser ZA

